

**Pressure Pulse Technology (PPT):
An Innovative Fluid Flow Technique and Remedial Tool**

TJT (Tim) Spanos and Brett Davidson
Wavefront Energy and Environmental Services Inc.

INTRODUCTION

A heart pulses blood through arteries and veins, with the nature of the pulse very dependent on the size of the animal. For example a humming birds heart beats 60 times per second with a very tiny amplitude whereas a blue whales heart beat 3 to 5 times a minute and is about the size of a Volkswagen beetle. It is the same pressure pulsing action that has been applied to environmental applications such as:

- Mobilizing and enhancing recovery of LNAPL's and DNAPL's
- Placement of chemicals such as surfactants and oxidants
- Introduction of bioactive agents and nutrients in a well dispersed manner
- Stabilization of permeability channeling or viscous fingering
- Increasing the basic flow rate so as to shorten any clean-up activity
- Enhanced placement of grout or other binding agents
- Unplugging, or rehabilitation of water wells through the mechanical perturbation

The permeabilities that are encountered in groundwater remediation range from milidarcies to hundreds of darcies. Thus, requiring pulsing systems that vary by many orders of magnitude in frequency and amplitude. An important point to be made is that PPT is not a stand-alone technology but rather an enabling technology. It yields improved reservoir conformance and injectivity. PPT is a patented technology, which is used by Wavefront Energy and Environmental Technologies for environmental and oil field applications. It is also licensed to Top Gun for oil field workovers in Alberta, to Halliburton Energy Services for exclusive oil field applications outside North America and non-exclusively to ERM of Boston, MA for environmental applications.

PPT uses periodic hydraulic excitations to introduce hydraulic strain energy into the saturated formation. This energy is effective in geologic materials exhibiting elastic properties, (including unconsolidated sediments; sedimentary rocks), dislodges blocked matter, opens perforations, increases pressure, re-establishes connectivity to reservoir pressures and generally enhances or restores the formation's permeability and a well's capacity to produce fluids. In PPT porosity plays a fundamental role as a dynamic variable that couples with fluid pressure to allow for fluid transport through the porous medium.

Perhaps most significantly, PPT disperses injected reagents at the pore scale by elastically dilating the matrix. This effectively causes a combining of the gradual input of an active agent, such as a chemical or a biologically active agent, with the contaminant.

PPT implementation
wellbore, generating
fronts, suppressing
contaminant. Further
remobilized and re
residing at residual
standard static flow
extra inertial energy
the capillarity blocks

THE EQUATIONS

Reference to Landau
 The fluid attenuation

$$a_{hf} = \frac{1}{2} \frac{\mathbf{m}_f}{K} \frac{h_o (\mathbf{a}_1 + \dots)}{\mathbf{r}_{hf}}$$

$$b_{hf} = \frac{2}{3} \frac{(\mathbf{m}_f + \mathbf{a}_1 \mathbf{s}_M)}{\mathbf{r}_{hf}}$$

Equation (5) fluid
 associated with the p

Finally, it is important to note that at all times the following statement of porosity diffusion is satisfied, and that this is a statement of conservation independent of Newton's Second Law of Motion, therefore it is necessary to achieve physical completeness of the problem statement.

(11)

$$\frac{\partial \mathbf{h}}{\partial t} = \mathbf{d}_s \nabla \cdot \mathbf{v}_s - \mathbf{d}_f \nabla \cdot \mathbf{v}_f$$

Numerical solutions for P waves and porosity waves

The previous system of equations yield two p waves, a porosity wave and a porosity diffusion process. It is the porosity wave that we use in environmental groundwater remediation processes. This wave is very frequency dependent and the frequencies required to propagate a porosity wave through a porous medium of given rock properties and permeability may be determined numerically. Figures 1 and 2 show the porosity wave speed verses wave period for silica sand and water of various permeabilities. In figure 1 the x axis is linear and in figure 2 it is logarithmic. Figure 3 shows the spatial attenuation verses period for a 1 Darcy medium composed of silica sand and water. Figure 4 shows the wave speed verses frequency for a 1 Darcy medium composed of silica sand and water.

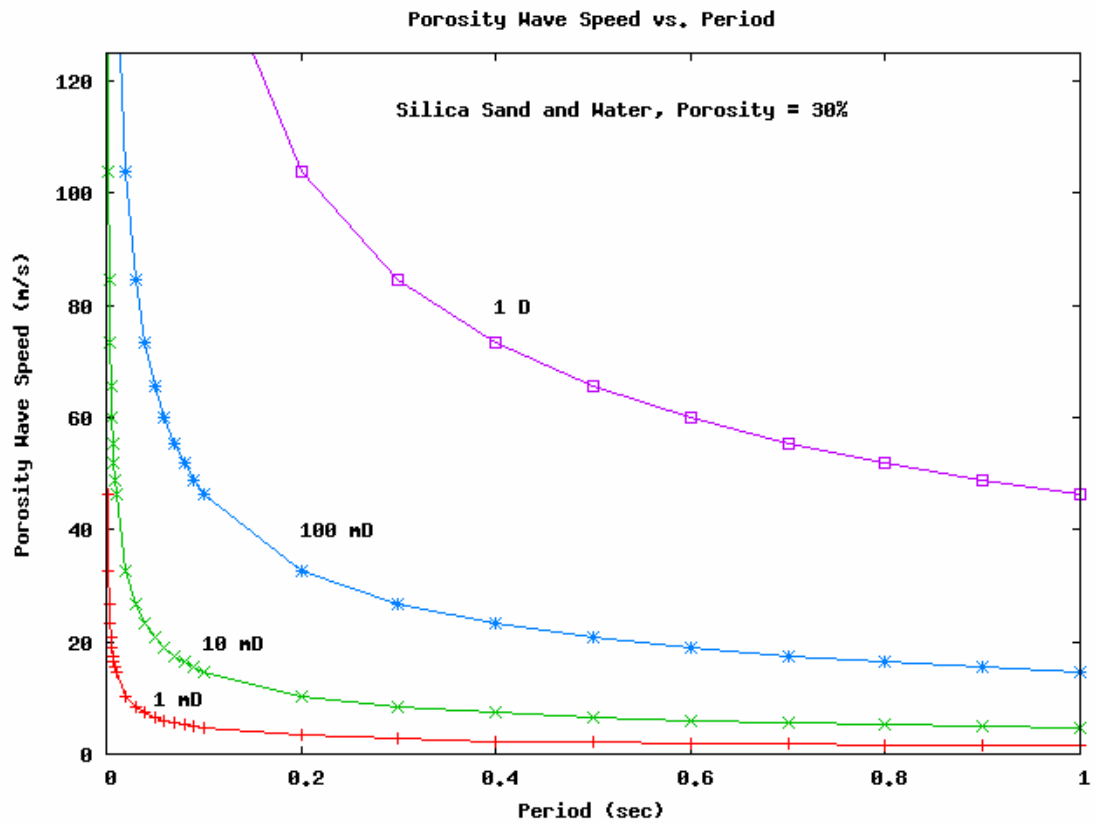

Figure 1: Porosity wave speed verses period on a linear scale for a porous media composed of silica and water. The porous media all have 30% porosity but differing permeabilities of 1 millidarcy, 10 millidarcy, 100 millidarcy and 1 darcy.

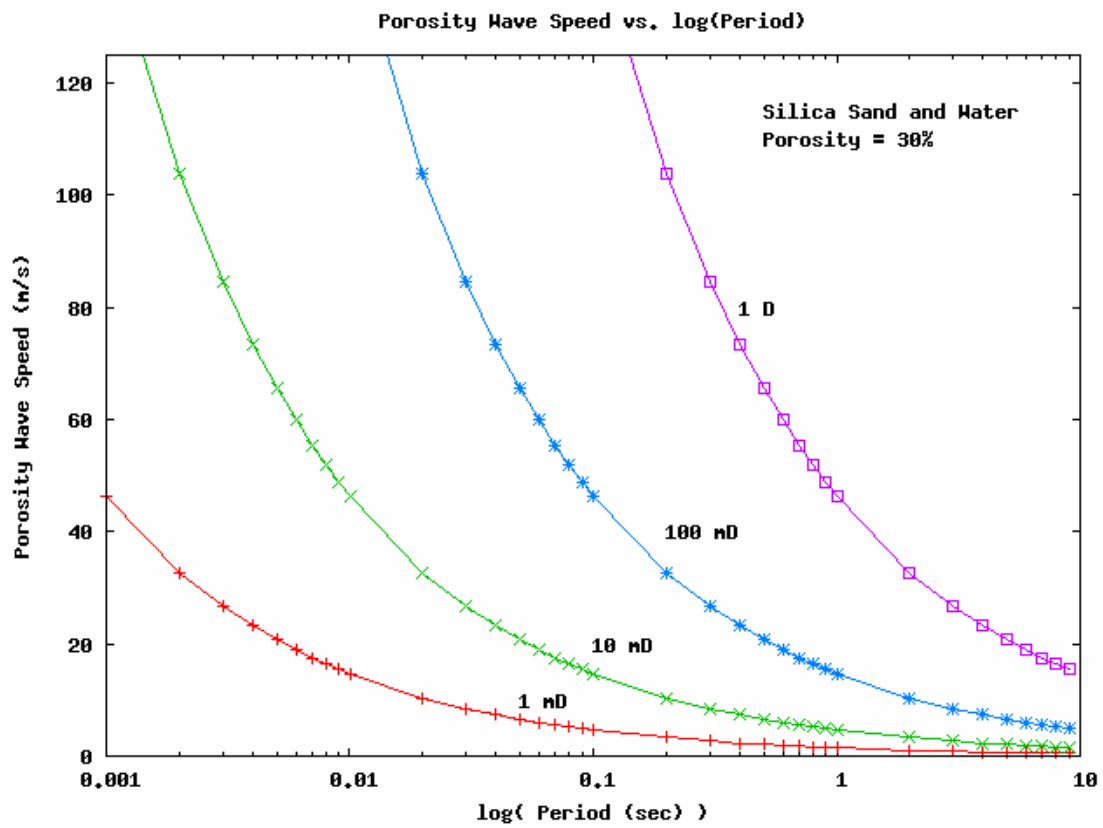

Figure 2: Porosity wave speed verses period on a logarithmic scale for a porous media composed of silica and water. The porous media all have 30% porosity but differing permeabilities of 1 millidarcy, 10 millidarcy, 100 millidarcy and 1 darcy.

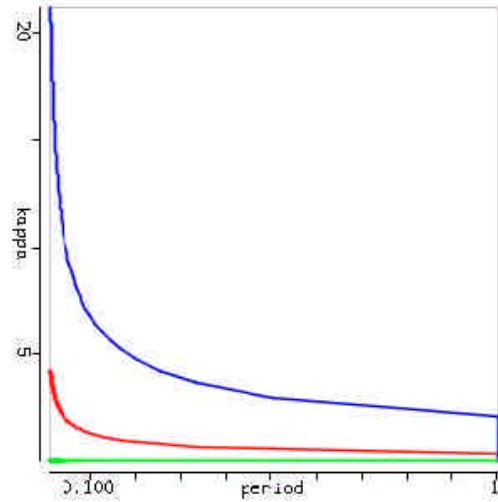

Figure 3: Attenuation verses period for a porous medium composed of silica and water with 30% porosity and 1 darcy permeability.

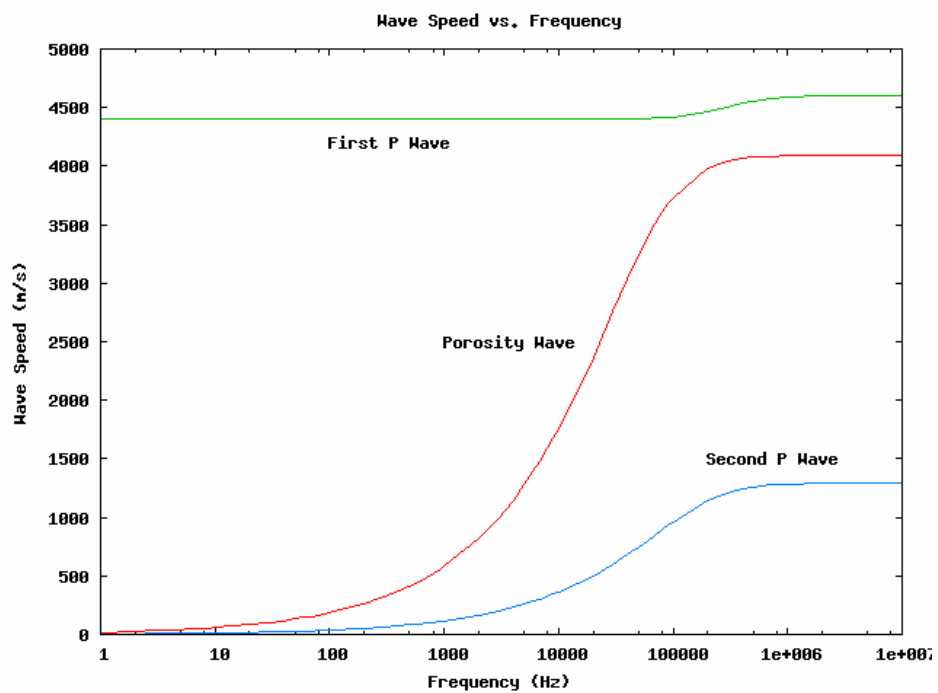

Figure 4: Wave speed versus frequency for the first and second P waves and the porosity wave over a range of 0 hertz up to the megahertz range.

LABORATORY MEASUREMENTS OF PPT

Two types of flow cell are used in the physical laboratory tests, cylindrical and rectangular. The cylindrical cells are as small as 70 mm f × 150 mm long and as large as 150 mm f × 1000 mm long (e.g. Figure 5). In these cells, sand is poured in, densified using vibrodensification, and sealed. In some cells, a 1 MPa axial stress is applied to the dense sand pack through a piston. Cells are equipped with lateral orifices for installation of pressure transducers or other devices such as accelerometers or geophones. The cells that are not stressed can be inclined at any angle. Rectangular flow cells are also used for pressure pulse tests (Figure 6). These are parallel plates (0.15 and 0.75 m²), of glass 20–30 mm apart that are placed vertically and filled with sand. Once filled, the end platens that control the inplane flow conditions are replaced, so that all the sand in the model is rigidly held in place. As with the cylindrical models, the rectangular cells can be used in any orientation, so that flow in the cell is “downhill” or “uphill”, depending on the goals of the test. The flow boundary conditions on the cells are straightforward. All walls are impermeable (no flow), entry regions in the cylindrical cells are generally small so that the majority of the flow is one-dimensional along the axis of the cylinder, and convergent flow to the exit orifice is allowed for tests where sand is allowed to flow. Coarse-grained sand or filter stones of high permeability are used at flow ends when a fine-grained sand medium is used in the cell. Sand can be restrained or allowed to move under the large seepage forces that develop near the exit orifice. A commercial data acquisition system is used to take measurements from the pore pressure transducers used in the various cells. The rectangular cells can be photographed under back-lit conditions to give some idea of frontal displacement efficiency, depending on liquid types. A picture of a flat cell and the pulsing system is shown in Figure 7

Figure 8 shows the increased flow rate during pulsing and a return to darcy flow whenever pulsing is stopped. This experiment is done in a rectangular cell, which has also been used to show increased dispersion and greater displacement efficiency than can be achieved through steady state flow (c.f. Zschuppe 2001).

Figure 9 shows the pressure increase along the cylindrical cell during pulsing. The porosity wave speed in this glycerine silica sand medium is observed to be 8 m/s and successive pulses are observed to build up the pressure in the medium. When pulsing is stopped the pressure is observed to be reduced through diffusion.

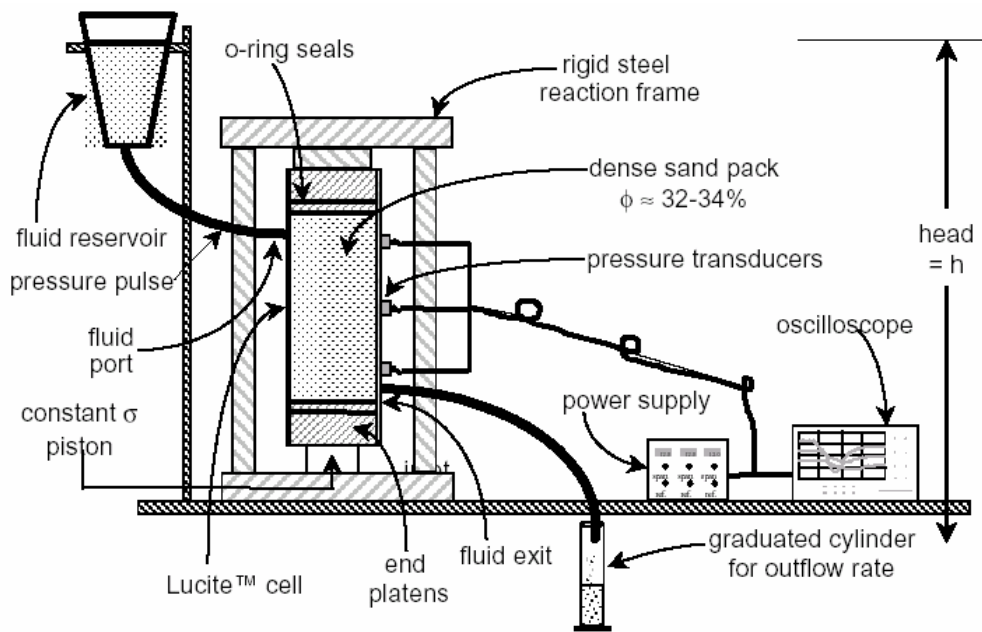

Figure 5: Cylindrical cell

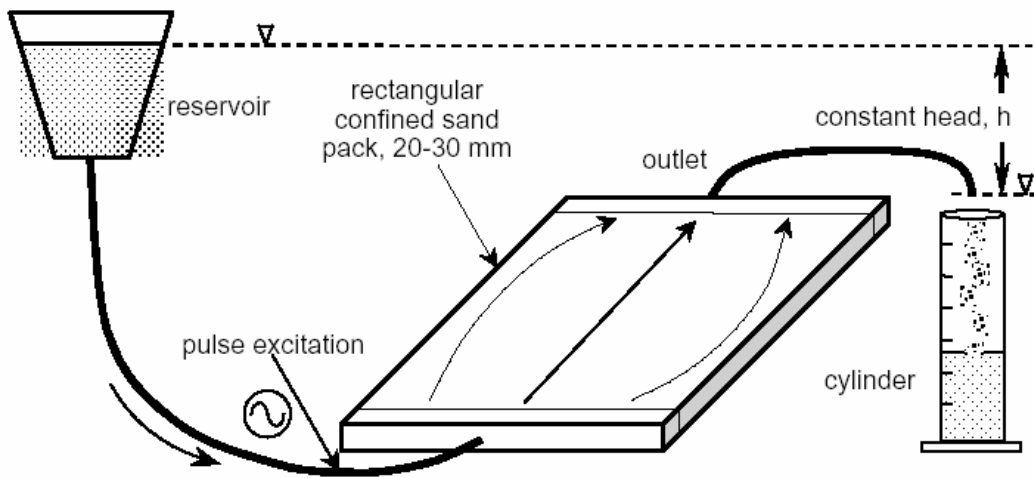

Figure 6: Rectangular cell



Figure 7: The pulser here consists of a tank containing fluid at a fixed pressure. A solenoid is opened causing the pressurized fluid to enter the cell over a 10^{th} of a second. That solenoid is then closed and another solenoid is opened allowing the pressure to go back to ambient conditions over a period of a second.

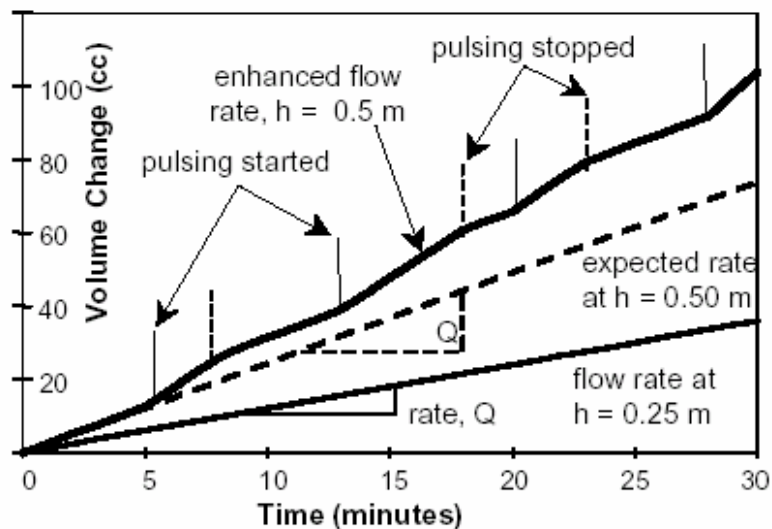

Figure 8: Volumetric flow rate versus time. The lower line represents the observed darcy flow at a .25 meter head. The dotted line represents the continuation of the Darcy flow at a .50 meter head after 5 minutes when pulsing begins. Note that when pulsing is stopped the volume versus time line is parallel to the dotted line.

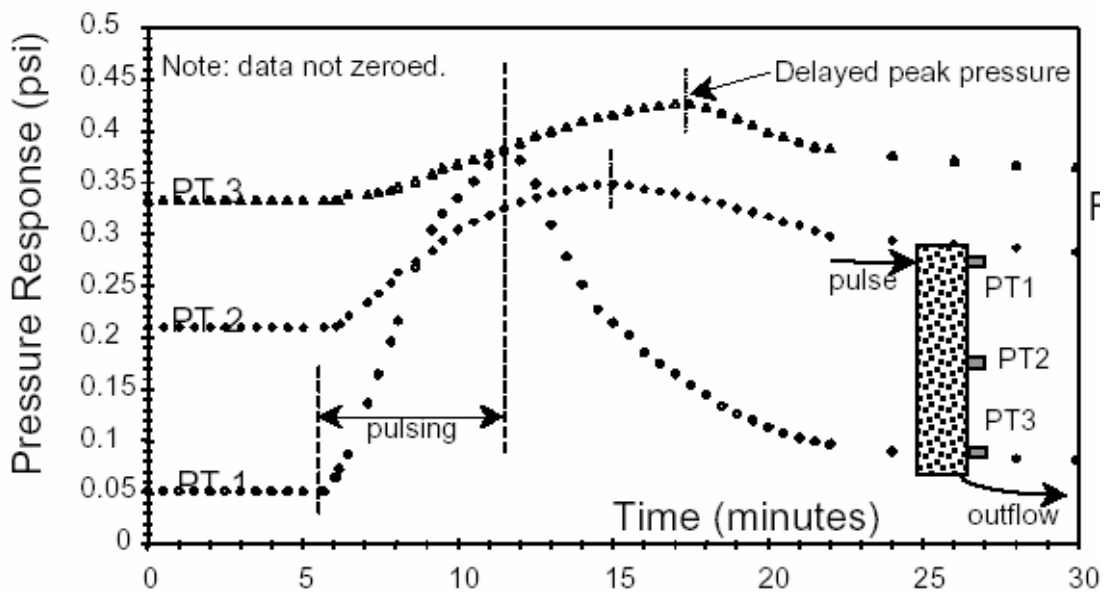

Figure 9: Pressure increase at three positions along the porous medium during and after pulsing. The medium is silica sand and glycerine. The lines are separated so they only represent the relative change in pressure at the position verses time.

CASE HISTORIES

Queens, New York. The site (Figure 10) is the location of a former substation contaminated by dielectric fluid, an LNAPL. A five-day PPT waterflood pilot was undertaken to evaluate the efficacy of PPT in the mobilization of residual NAPL. Prior to the initiation of PPT, a static waterflood was performed to establish injectivity rates as well as water and free product levels in offset monitoring wells. This data was used as the base line for the comparative analysis of PPT.

The injection well was screened at 18 feet, one foot below the water table to ensure injection occurred at, or near the water table. The majority of monitoring and recovery wells were within 20 – 30 feet of the injection point. An initial test was done in January 2004 but was shortened due to abnormally cold weather that froze the water supply lines. However, even during the short tenure of the trial positive affects arising from PPT was evident from interface probe measurements in monitoring wells. The project was continued in March 2004 and initial results indicate that PPT had positive affects on the mobilization of the NAPL. Most evident was water level changes, changes in product thickness and measurability, and product recurrence following bailing.



Figure 10: Test site in Queens, New York.

Tonawanda, New York. Wavefront performed a pilot PPT program at a former coal tar gas plant in Tonawanda, NY. The site was an active pump-and-treat to recover a viscous NAPL. The zone of interest was located 20 feet below grade and consisted of two geologic units: a low permeability alluvial zone underlain by a higher permeability gravel zone.

For the first 25 days, a traditional static waterflood was applied by pumping surface water at 2.3 liters a minute (0.6 gpm) into a screened well that intersected both geologic units. The waterflood effects on pressures were measured in offset wells in each unit at 7.5 feet and 15 feet away from the injection point. The initial waterflood was followed by PPT injection at the same injection rate. Within hours, head increased in the alluvial unit and decreased in the gravel unit as compared to pressures seen during the static injection (Figure 11). In other words, the application of PPT resulted in more water flow through the lower permeability unit, showing the capability of PPT to limit the effect of permeability contrasts.

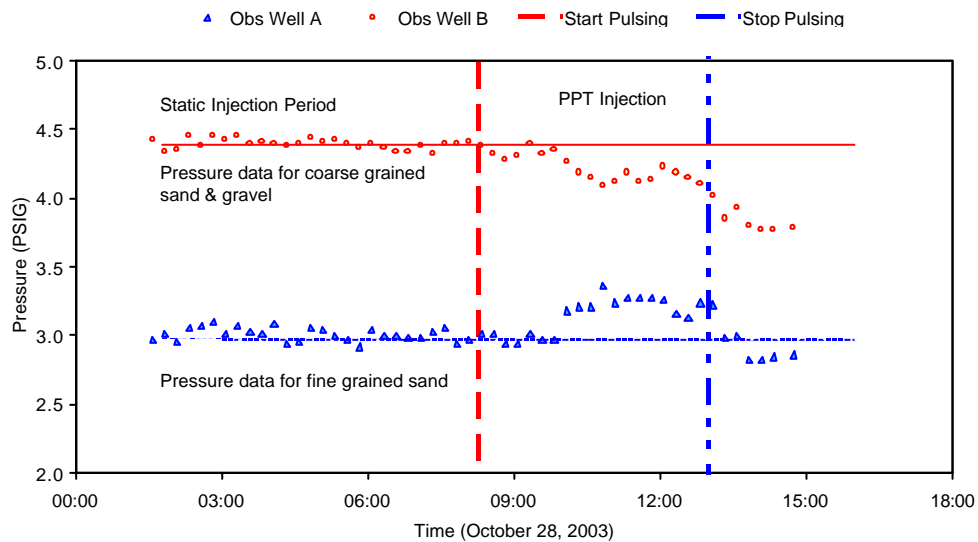

Figure 11: Pressure changes in the offset well 7.5 feet from the injection point

Unfortunately, the well soon failed and injection water started coming to surface immediately along side the casing between the casing grout-soil contact. It appeared that the failure was due to the lack of competent grouting. Pressures during the PPT injection had stayed below recommended safety limits.

Austin, Texas. The Cape Fear Wood Preserving site in Fayetteville, North Carolina is a Superfund site with over 78,000 kg (172,000 pounds) of creosote contamination. Current efforts have focused on compiling a geosystem model from ground penetrating radar (GPR) surveys; laser induced fluorescence (LIF) surveys, drilling and DNAPL sampling. A bench treatability study was undertaken to evaluate the effectiveness of PPT to enhance surface dispersion and improve creosote recovery.

For the study a total of nine experiments were run on creosote contaminated porous media comparing static waterfloods, PPT waterfloods, and PPT surfactant floods. Both site soils and Ottawa sands were used in soil columns and a 2-d test cell. The 2-d test cell with interior dimensions of 25 x 36 x 1.9 cm is useful for determining 2-d fluid distribution. This effect is usually ignored by treatability studies, but a key factor when considering the usage of PPT.

The study indicated that PPT significantly enhanced the performance of both water flooding and surfactant flooding. The static waterfloods all recovered less than 50% of the creosote while the PPT waterfloods showed creosote recovery improvements of 10-15% over static flooding. When applied in conjunction with surfactant flooding the performance improvement was impressive. In the column and test cell experiments, PPT and surfactants removed 99.7% and 97% of the creosote, respectively. In the field soil experiments, a combination of surfactant flooding and PPT recovered 99.8% of the creosote with a starting saturation of 10.5% after 3.3 pore volumes of surfactant. When the creosote saturation was increased to 85%, 95.8% of the creosote was recovered after only five pore volumes of PPT injected surfactant (Figure 12).

Broomfield, Colorado. PPT was used in a comparative study for the injection of a bromide tracer in very low permeability silty clay in Broomfield, CO. The comparative study had equal volumes of the bromide tracer injected by (1) conventional pressure injection, and (2) PPT injection. Of importance during the comparison was the distribution of the tracer in the subsurface and the time taken for the tracer to reach independent real-time monitoring points. PPT outperformed conventional injection practices having the distribution of the bromide seen in monitoring wells both up gradient and down gradient from the injection point. As well, bromide was seen in a larger number of well points. Conventional injection distribution was limited to down gradient wells and a scattering of wells showed traces of bromide. Additionally, through PPT injection the bromide tracer was seen in the independent monitoring wells in half the time taken using conventional injection, which demonstrates the positive attributes of PPT accelerating fluid flow.

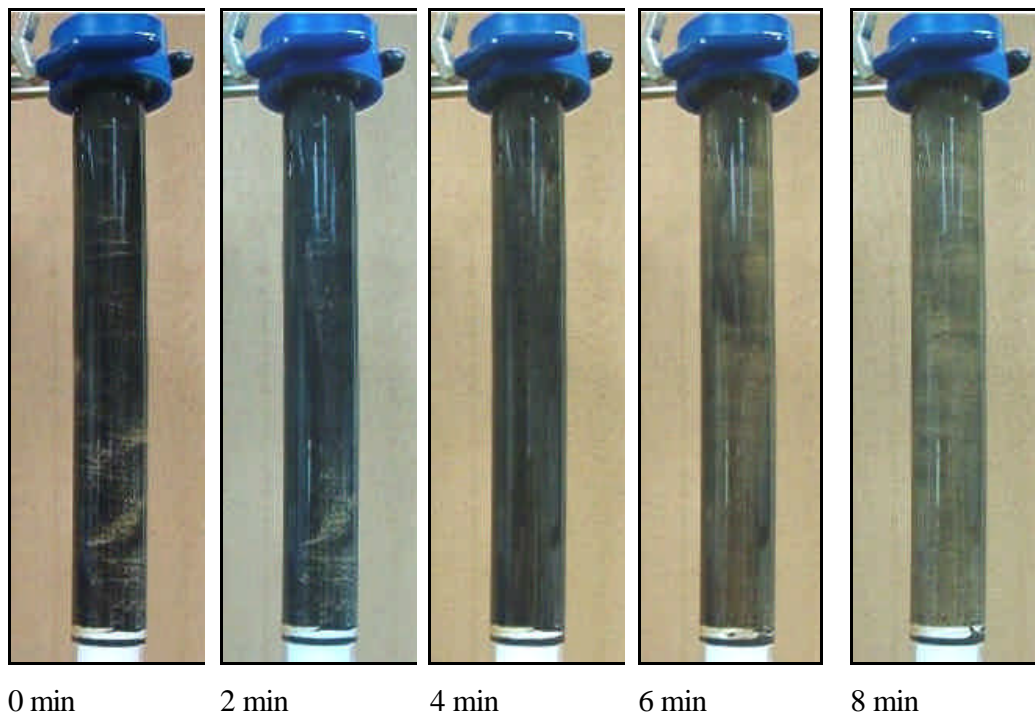

Figure 12: PPT surfactant flood on an 85% creosote saturated site soil column.
Total creosote recovery was 95.8% after five pore volumes.

Cape Canaveral, Florida. In January 2004, Wavefront conducted a single-well pilot project to evaluate the performance of PPT when injecting an emulsified zero-valent iron (EZVI). The project was run in Cape Canaveral where EZVI is being assessed as an *in-situ* treatment of a DNAPL composed primarily of trichloroethylene (TCE).

The well configuration was composed of one injection well flanked by two geoprobe offset wells, both at 3.5 feet from the injection well and approximately 130° from each other with respect to the injection well. The offset wells had Flute liners installed, which readily absorb oils and are designed to change colour when they come into contact with solvents.

During the PPT testing phase, the EZVI was injected in periodic stages with water until the injected volumes of EZVI and water totaled 65 gallons and 75 gallons, respectively. Figure 13 shows a sample pulse taken during the water injection with the pulse frequency decreased slightly for clarity. The actual pulse frequency was 40 pulses per minute. Following the injection, the Flute liners were pulled to evaluate the success of the test. Both Flute liners showed evidence of oil staining at 12-14 feet, with the darkest staining at approximately 13 feet. There was also some evidence of oil staining around 4 feet and 17 feet below surface.

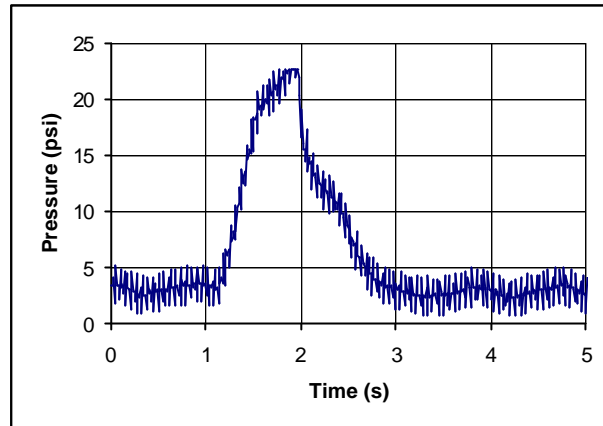

Figure 13: A pressure pulse with a sharp rise time and slightly slower decay time.

REFERENCES

L.D. Landau and E. M. Lifshitz, *Fluid Mechanics*, Pergamon, Toronto, 1975.

R. Zschuppe, *Pulse Flow Enhancement in Two Phase Media*, M.Sc. thesis University of Waterloo, 2001.